



Electric Service Guidelines

**Underground Service
Section 400**

October 2007

Oncor Electric Delivery Company

ELECTRIC SERVICE GUIDELINES

These Electric Service Guidelines supersede all prior issues of Electric Service Guidelines issued by Company and become effective with all construction **on** or **after October 15, 2007**. For more information call the Company at 1-888-313-6862 or visit our website at

<http://www.oncor.com>

For underground cable locates call Dig TESS at 1-800-344-8377.

FOREWORD

**SECTION 100
GENERAL INFORMATION**

**SECTION 200
CLEARANCES**

**SECTION 300
OVERHEAD SERVICE**

**SECTION 400
UNDERGROUND SERVICE**

**SECTION 500
METERING AND ASSOCIATED EQUIPMENT and
CONNECTOR APPLICATION TABLES**

**SECTION 600
TEMPORARY SERVICE**

FOREWORD

This booklet is issued by Oncor Electric Delivery Company (Company) for use by Customers and their agents.

This booklet should be used as a guide in planning the installation of electrical equipment and methods of receiving electrical power and energy from the electrical delivery system of Company.

If service methods other than the examples discussed in this booklet are required, the Customer is to obtain written Company approval prior to letting bids and installing equipment.

Where local inspection authority is not involved, meter installations should be wired in accordance with the latest edition of the National Electrical Code or Company specifications when the Company specifications exceed those of the National Electrical Code.

The information presented herein will be revised periodically to reflect changes which may develop. **It is the Customer's responsibility for obtaining the latest revision.** The latest revision can be obtained at:

http://www.oncor.com/electricity/construct/guidelines/const_guide.aspx

NOTE: [October 2007 Revisions are highlighted in yellow on this INTERNET posting copy only]

SECTION 400 – UNDERGROUND SERVICE

400.01 General

Underground service is provided to Customer who meets Company requirements set out herein and pays to Company any amount due. Cash payments or other arrangements satisfactory to Company are made by Customer prior to Company's beginning construction. All underground facilities included in the cost estimates are provided, installed, owned and maintained by Company.

Where Company provides electric delivery service underground, Company retains the right to limit electric delivery service to such underground, network, and/or dual feed distribution systems.

400.02 Underground Service Lateral for Residential Customers and Secondary Service Customers Served from Overhead Transformation

The Company owns and maintains the service lateral conductor and raceway. The Company installs the service lateral conductor. The Customer has the option of installing the raceway connecting the Company's distribution system to Customer's point of delivery (reference Section 500, Figure 5A). Where Customer installs or plans to install obstructions (asphalt or concrete walk, driveway, retaining wall, paved parking lot, etc.) in the path of Company's service lateral, Company will require Customer to provide and install raceway for Company's service lateral to Company specifications. Should Customer not install necessary raceway for service lateral prior to the installation of obstructions or should Customer's service route change after the installation of obstructions where no raceway exists for new service lateral location, Customer must make the necessary raceway installations prior to service lateral installations. Contact Company for details.

Customer is to establish final grade before service lateral can be installed. Any change in final grade which results in the lowering or raising of service lateral raceway or associated equipment is at the expense of the Customer.

When installed by Company, service lateral will be run in a straight line. A clear path wide enough to permit passage of excavation equipment is required. It is the Customer's responsibility to clear all obstructions before service lateral installation starts. Customer is also responsible for marking or exposing any plumbing. The Company will not be responsible for damaging private plumbing.

Company owned service lateral raceways are to be located on the exterior of the building.

400.03 Underground Services to Secondary Service Customers Fed from Padmounted Transformers, Handholes, or Service Pedestals

Secondary Service Customers fed from padmounted transformers, handholes, or service pedestals are to furnish, install, own and maintain the service lateral conductors including raceway(s) to the device terminals. Customer will furnish and Company will install connectors and connect to terminals. Where fed from transformers, Customer conductor size shall be limited to 1000 kCMIL. See Section 500, Figure 5A for Company-Customer responsibility.

400.04 Underground Service, One Residential Meter

See Figure 4-A, page 8.

400.05 Underground Service, One Secondary Service Meter

See Figure 4-B, page 9.

400.06 Underground Service, Two or More Secondary Service Meters

See Figure 4-C page 10 and Figure 4D, page 11.

400.07 Underground Service, Meter Pedestal

See Figure 4-E, page 12.

400.08 Underground Service to Mobile or Manufactured Homes

Underground service to a mobile home shall be made in a manner as depicted in Figure 4-E, page 12. The meter socket shall not be mounted directly to the mobile home.

Manufactured homes, if equipped with **factory installed** service equipment, may be connected as depicted in Figure 4-A, page 8 if all three of the following requirements are met.

- (1) The manufactured home is secured to a permanent foundation by an approved anchoring system. Compliance with this requirement may be evidenced with **one** of the following:
 - (a) the manufactured home structure is included in the real property deed,
 - (b) the foundation and anchoring system is designed by a Texas licensed engineer or Texas licensed architect, or
 - (c) an affidavit from a home inspector is provided verifying that the foundation and anchoring system meets the Texas Administrative Code foundation and anchoring requirements for Manufactured Housing (TAC Title 10, Part 1, Chapter 80).
- (2) The service equipment complies with Article 230 of the National Electrical Code (NEC).
- (3) Bonding and grounding comply with Article 250 of the NEC.

Contact Company prior to installation of mobile or manufactured homes to determine service method.

400.09 Other Underground Services

For any situation that is not addressed, please contact Company for specific instructions.

Notes:

1. For temporary underground service, see Section 600, Figure 6-B.
2. For underground line locating services, please call 1-800-344-8377.

UNDERGROUND SERVICE ONE RESIDENTIAL METER

FIGURE 4-A

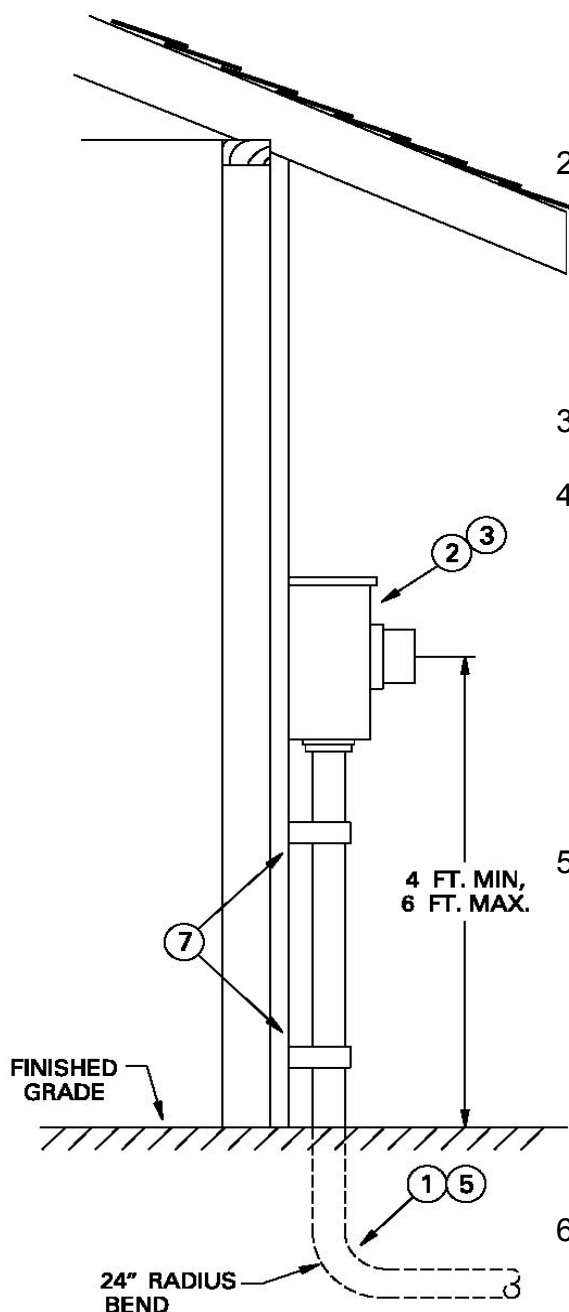

Notes:

1. Company owned service lateral conductors are installed by Company and line side (top) connections made up by Company. Customer's service conductors are installed and connected in socket by Customer.
2. Meter socket shall be provided, installed, and maintained by the Customer. Transockets, when required, shall be provided by Company and installed and maintained by Customer. **Customer load conductors may not exit top half of meter socket enclosure.**
3. Insulated conduit bushing is required for raceways terminating in meter socket.
4. Customer's grounding electrode conductor (#6 Cu min.) shall originate in the service entrance equipment and extend to an approved ground electrode. The grounding electrode conductor is permitted to be routed through the meter socket enclosure, but shall not terminate within. Company reserves the right to refuse installation of service contingent upon inspection of Customer's grounding connections.
5. Reference section 400.02, page 5 for Company or Customer responsibility for service lateral raceway installation. Schedule 80 PVC or Schedule 40 PVC (if permitted by local code) is required for underground service lateral raceway. **Rigid steel, IMC, or EMT is not allowed.** Contact Company prior to installation to determine service lateral raceway size (two inch is minimum).
6. The use of flexible metallic conduit, liquid tight flexible metallic conduit, and liquid tight flexible non-metallic conduit for service entrance raceway is prohibited, unless approved by the local inspecting authority.
7. Two 2-hole straps may be required by the inspecting authority.

UNDERGROUND SERVICE ONE SECONDARY SERVICE METER

FIGURE 4-B

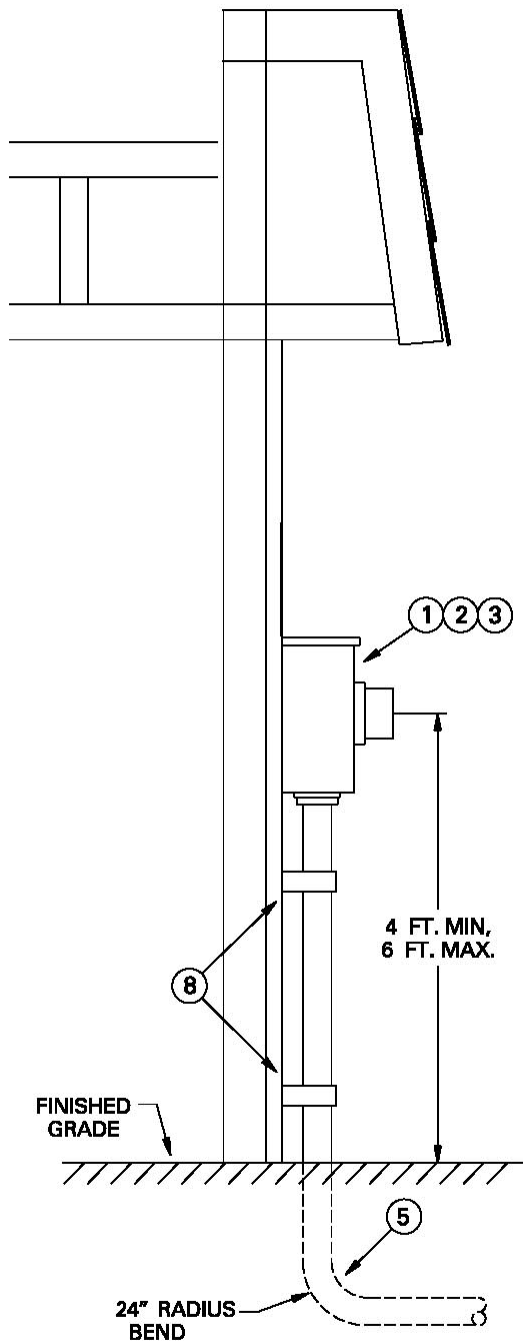

Notes:

1. See Section 500, Figure 5A for Company-Customer responsibility of source and load conductors and connection of these conductors.
2. Meter socket shall be provided, installed, and maintained by the Customer. Transockets, when required, shall be provided by Company and installed and maintained by Customer. All meter sockets (excluding transockets) require the line side conductors to be connected to the top meter socket terminals. **Customer load conductors for self contained meter sockets may not exit top half of meter socket enclosure.**
3. Insulated conduit bushing is required for raceways terminating in meter socket.
4. Customer's grounding electrode conductor (#6 Cu min.) shall originate in the service entrance equipment and extend to an approved ground electrode. The grounding electrode conductor is permitted to be routed through the meter socket enclosure, but shall not terminate within. Company reserves the right to refuse installation of service contingent upon inspection of Customer's grounding connections.
5. Reference section 400.02, page 5 and 400.03, page 6 for Company or Customer responsibility for service lateral raceway installation.
6. Schedule 80 PVC is required for Company owned underground service lateral raceways. **Rigid steel, IMC, or EMT is not allowed.**
7. The use of flexible metallic conduit, liquid tight flexible metallic conduit, and liquid tight flexible non-metallic conduit for service entrance raceway is prohibited unless approved by the local inspecting authority.
8. Two 2-hole straps may be required by the inspecting authority.

UNDERGROUND SERVICE, TWO OR MORE SECONDARY SERVICE METERS WITH SERVICE ENCLOSURE

FIGURE 4-C

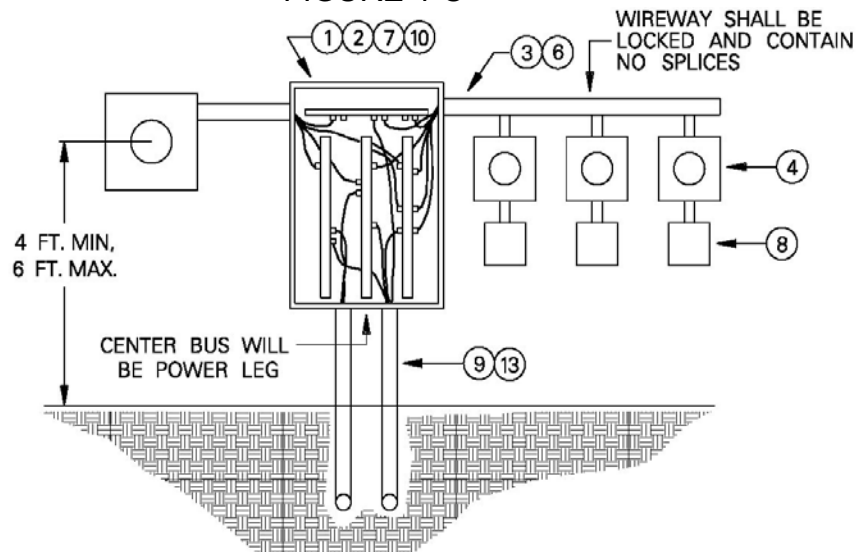

NOTES:

1. A service enclosure (see Section 500.08), installed by Customer on outside wall of building for Secondary Service installations through 2500 amperes and two or more meter sockets, is required. Contact Company for determination of service enclosure requirements. For multi-family installations, see Section 500, Figure 5-E.
2. Load conductors to meter sockets to be connected equally on both ends of bus bars to obtain full current rating of bus bars. Line conductors shall be connected to center of bus bars.
3. Conductors, gutters and raceways provided, installed and maintained by Customer.
4. Meter sockets shall be provided, installed and maintained by Customer. Transockets, when required, shall be provided by Company and installed by Customer.
5. For use on service voltages through 480 volts.
6. Service entrance conductors to be continuous from meter sockets to service enclosure.
7. Refer to Section 500, Figure 5-A for connector/conductor responsibility in service enclosures. Approved connectors, plated 3/8" minimum diameter bolts, belleville washers and oxide inhibitor are required for connections to plated aluminum bus.
8. Service switches, when installed near the service enclosure, should not interfere with service to an occupancy.
9. For service lateral installation refer to 400.02, page 5.
10. For underground services, the bottom section of the enclosure shall be reserved for the line side conductors. Load side conductors are not permitted to exit bottom.
11. Insulated conduit bushings are required for raceways terminating in the meter socket.
12. The use of flexible metallic conduit, liquid tight flexible metallic conduit, and liquid tight flexible non-metallic conduit for service entrance raceway is prohibited unless approved by the local inspecting authority.
13. Schedule 80 PVC is required for Company owned underground service lateral raceways. **Rigid steel, IMC, or EMT is not allowed.**
14. Each socket must be clearly and permanently marked to indicate each apartment or location served. **See Section 500.11.**

UNDERGROUND SERVICE, TWO OR MORE SECONDARY SERVICE METERS WITH METERPACK

FIGURE 4-D

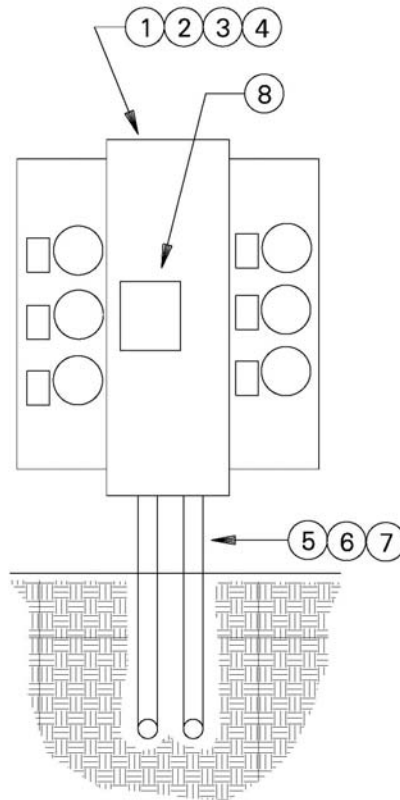

NOTES:

1. A meterpack, installed by Customer on outside wall of building for Secondary Service installations for two or more meter sockets, may be installed in lieu of a service enclosure. **Contact Company for approval of meterpacks prior to letting bids and installing equipment.** For multi-family installations, see Section 500, Figure 5-E.
2. Meterpacks provided, installed and maintained by Customer.
3. Refer to Section 500, Figure 5-A for connector/conductor responsibility in meterpack.
4. When utilizing meterpacks to serve Secondary Service Customers, lever operated bypass mechanisms are required for each individual meter socket.
5. For service lateral installation refer to 400.02, page 5.
6. The use of flexible metallic conduit, liquid tight flexible metallic conduit, and liquid tight flexible non-metallic conduit for service entrance raceway is prohibited unless approved by the local inspecting authority.
7. Schedule 80 PVC is required for Company owned underground service lateral raceways. **Rigid steel, IMC, or EMT is not allowed.**
8. **It is the Customer's responsibility to determine local code requirements concerning meterpacks with main switches or main circuit breakers prior to installing equipment.**
9. Each socket must be clearly and permanently marked to indicate each apartment or location served. **See Section 500.11.**

UNDERGROUND SERVICE METER PEDESTAL

FIGURE 4-E

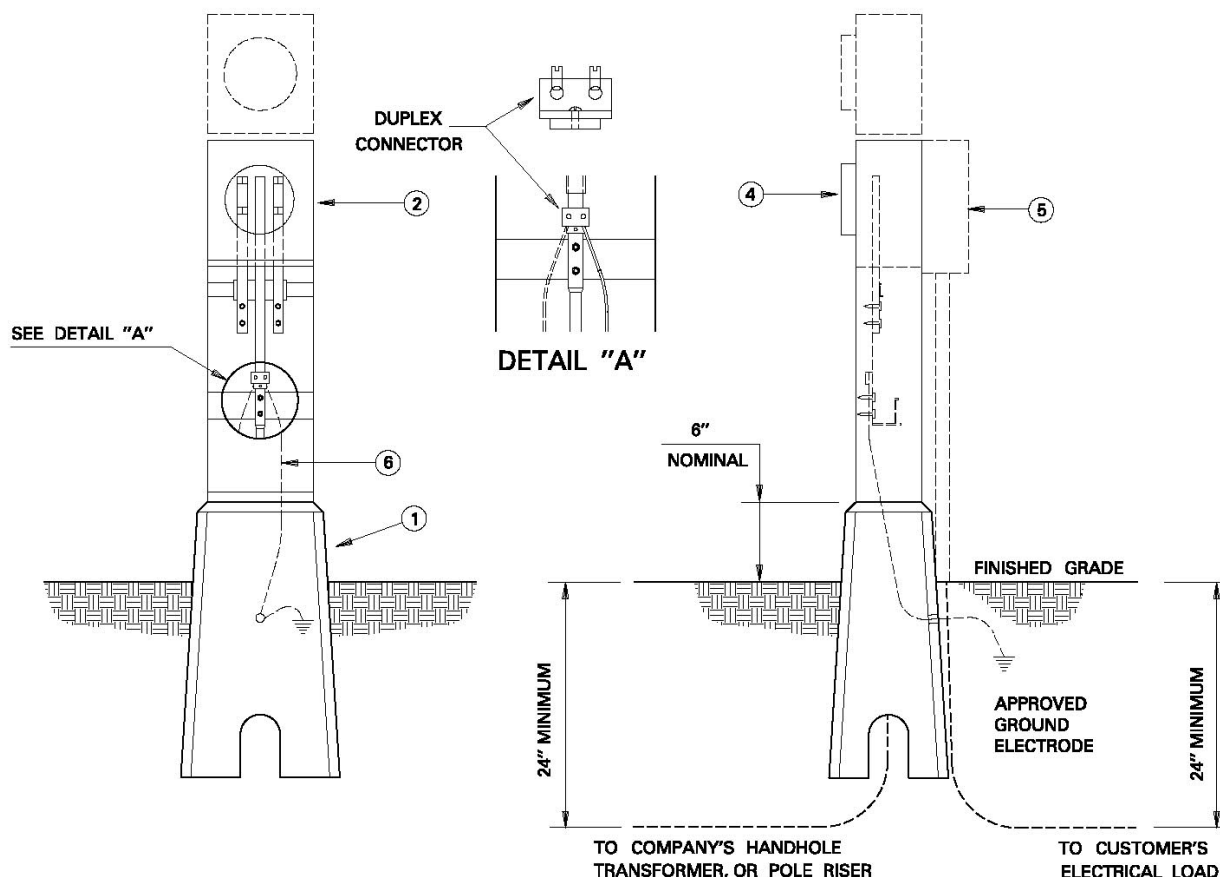

NOTES:

1. Precast foundation provided by Company.
2. Above ground meter pedestal provided, installed and maintained by Customer. Customer provides anchor clips and bolts with meter pedestal.
3. Service lateral or source conductors provided and installed as per 400.02, page 5.
4. Four feet clearance is required from meter side of pedestal to any obstruction or structure.
5. Customer service equipment may be installed on meter pedestal in accordance with all applicable codes.
6. Customer may connect grounding electrode conductor to duplex connector on neutral bus. The grounding electrode conductor (#6 Cu min.) shall connect to an approved ground electrode. Company reserves the right to refuse installation of service contingent upon observing an unsafe Customer connection.
7. Alternate Design- Customer shall obtain Company approval of any alternate design prior to installation.

Information to be Supplied by Electricians to Pull Meters On Self-Contained Meter Bases

Template for information required when calling the electrician voice mailbox at 1-800-518-2374.
See Section 500.02.

Electrical Contractor's Company _____

Employee's Name _____

Address where work is to be done _____

City _____

Work to be done

Will work require an electrical inspection? Yes No

Date meter will be pulled _____

Date meter will be replaced _____

Contact phone number for clarifying information _____

DO YOU KNOW THE LAW?

Texas Law & OSHA Regulations

To ensure safety and the protection of the public, Chapter 752 of the Texas Health and Safety Code makes it unlawful for unauthorized persons to **move or be placed or bring any part of a tool, equipment, machine, or material within six (6) feet** of live overhead high voltage lines. Contractors and owners are **legally responsible** for the safety of construction workers under this law. This law carries both criminal and civil liability.

Additionally, OSHA Regulations restrict unauthorized persons from **approaching or operating any equipment or machines within ten (10) feet** of live overhead high voltage lines.

For lines to be turned off, moved, or other arrangements, call your Retail Electric Provider.

Some local Electrical Codes require structures to be located a safe distance away from live overhead high voltage lines as defined by the National Electrical Safety Code.



**Be Safe
Around Electricity**