

Specifications for Manhole and Duct Structure Facilities



Specification MMD - 5
Revision 1, February 2005



SUMMARY OF SIGNIFICANT changes in MMD-5 DATED February 2005
PAGE 1 OF 2

COVER SHEET – added to match DDS 1 through 4

INDEX – updated to page numbers and Titles within the document

Page 1 - II. DEFINITIONS - Updated Company Name to TXU Electric Delivery

Page 3 - IV GENERAL –
C. TRENCH SAFETY - updated to read...”by a registered professional engineer in the State of Texas)”...

Page 3 - E. MATERIALS – GI (GALVANIZED IRON) MATERIALS ARE NO LONGER ALLOWED IN UNDERGROUND INSTALLATIONS – ALL NEW CONSTRUCTION IS PVC CONDUIT AND BENDS.
ONE EXCEPTION: GOING UP A POLE MAY BE GI ABOVE THE GROUND LINE.

Page 4 - H. WORKING HOURS – updated to read...” TXU ELECTRIC DELIVERY inspector shall be notified a minimum of 2 hours prior to the delivery of concrete and shall be present during placement.

Page 4 – **NEW** N. DESIGN CHANGES – Contractor shall submit a written request to the appropriate TXU ELECTRIC DELIVERY Authorized Personnel prior to any modification to the original design drawings that will change the number of bends or add 10 percent or more to the overall conduit length found on the original design plan. This written request must be provided prior to implementation of change.

Page 6 - VI. CONTRACTORS RESPONSIBILITY -
B. CONCRETE ENCASED DUCT STRUCTURE INSTALLATION

5. “Minimum” of DB-60 PVC material for bends and elbows. All 6 inch bends shall have a 36 inch radius.

GI Bends are no longer allowed in a duct system.

Page 7 - 6. clarified that the ground rod is to be “**copper clad** ground rod...”

Page 8 - E. SUBSTATION FEEDER EXIT INSTALLATION

2. clarified that drawing “GNDREPAIR” is page 22 of this document



SUMMARY OF SIGNIFICANT changes in MMD-5 DATED February 2005
PAGE 2 OF 2

ATTACHMENTS:

PAGE 12 – TYPICAL DUCT SECTION

Revised to indicate minimum of 30 inches backfill over concrete encased duct.

PAGE 14 – 4 WAY MANHOLE

Revised to indicate that the typical spacing of the Racking Inserts is 8 inches on center. (It was 12 inches on center per the previous MMD-5.)

PAGE 18 – MANHOLE NECK

Revised to indicate the Manhole Neck extensions are as follows:
Namely: 6, 12, 18, 24 and 36 inches

PAGE 20 – TERMINATION OF CONDUIT LINE FOR FUTURE USE

Revised to clarify the dowelling. Added sentence to the INCOMPLETE DUCT LINE Item 2. “Install #5 dowel with 8 inches minimum embedment.

PAGE 20 – TERMINATION OF CONDUIT AT RISER POLE

Revised to indicate that all underground conduit and bends shall be PVC. The use of GI is limited to above grade and UP THE POLE only.

PAGE 23 – SWITCHGEAR PAD DETAIL

Completely replaced this drawing with most current deep well drawing.

PAGE 24 – MANHOLE FRAME AND COVER

Revised to latest Company drawing with TXU Electric Delivery Logo.

SPECIFICATIONS FOR MANHOLE AND DUCT STRUCTURE FACILITIES

Specification Number: MMD - 5

Table of Contents

		Page #
I.	Scope	2
II.	Definitions	2
III.	Codes & Ordinances	2
IV.	General	2
V.	Company Responsibility	4
VI.	Contractor's Responsibility	5
VII.	Variances	11
VIII.	Attachments	11
	Trench Section Conduit Detail (Typical Duct Section)	12
	4-Way Manhole Detail	13
	3-Way Manhole Detail	15
	2-Way Manhole Detail	17
	Manhole Neck Detail	18
	5' x 5' Manhole Concrete Entrance Pad	19
	Termination of a Conduit Line for Future use.	20
	Termination of a Conduit at Riser Pole.	21
	Substation Ground Wire Repair Detail	22
	Switchgear Pad Detail	23
	Manhole Frame and Cover	24

I. SCOPE

This document, when applied in conjunction with the construction drawing(s), represents the minimum requirements and specification for TXU ELECTRIC DELIVERY manhole and conduit systems. (duct structure)

II. DEFINITIONS

- A. Company: TXU ELECTRIC DELIVERY and its designated representatives
- B. Contractor: Individual or firm performing work for TXU ELECTRIC DELIVERY

III. CODES AND ORDINANCES

All applicable codes and ordinances shall be followed in the design and construction of the manhole and conduit line system. Included, but not limited to, are the following:

- A. Local City Building Code
- B. The National Electric Safety Code (NESC)
- C. The contractor shall be familiar with and shall comply with all applicable requirements of these specifications and with OSHA requirements. If there are any conflicts or omissions, the OSHA requirements shall be met. Any conflict or omission shall not relieve the contractor of responsibility of complying with OSHA requirements.
- D. Local City Location and Coordination Policy (if applicable)
- E. The American Concrete Institute (ACI)
- F. The American Society for Testing and Materials (ASTM)
- G. Texas State Department of Highways and Public Transportation - Utility Accommodation Policy
- H. Local, city, state and federal environmental regulations.

IV. GENERAL**A. UTILITIES**

1. The Contractor shall locate and protect all existing utilities, whether indicated on the design drawings or discovered during the work. The Contractor shall immediately notify the Company's Authorized

Representative when any utility not previously indicated or inaccurately indicated on the design drawing is discovered.

2. The Contractor shall coordinate with the utility owner and shall allow entrance, opportunity, and ample time for all utility relocations, extensions, and modifications necessitated by the work.
- B. DEWATERING - The Contractor shall remove all existing standing water located on the work site. Furthermore, the Contractor shall maintain the work site, including excavations, pits, and all other depressions, free from surface water.
1. Drainage
 - a. The Contractor shall stockpile all materials required for or resulting from the work in a manner which will minimize the obstruction of the natural flow.
 - b. When operations are interrupted by unfavorable weather conditions, the Contractor shall prepare the work site to avoid ponding and erosion.
 2. Clearing - No trees shall be cut or removed, except as directed by the Company's Authorized Representative. The Contractor shall use proper care to prevent damage to trees which are to remain on site.
- C. TRENCH SAFETY - The Contractor is responsible for obtaining and implementing the trench safety program. Three copies of the trench safety specification (certified by a registered professional engineer in the State of Texas) shall be supplied to TXU ELECTRIC DELIVERY before construction begins.
- D. CONSTRUCTION SCHEDULE - The Contractor shall supply a construction schedule to TXU ELECTRIC DELIVERY before construction begins.
- E. MATERIALS - This is a turnkey job. The Contractor shall supply all materials for this job including manholes, necks, frames and covers, con-seal, ground rods, PVC conduit, PVC bends, PVC couplings, tie-wraps, conduit spacers, PVC adhesive, concrete, select backfill, pull ropes, pre-cast switchgear pads, etc., per TXU ELECTRIC DELIVERY Specifications unless otherwise specified, in writing.
- F. SURVEY - Unless otherwise noted the Contractor shall be responsible for providing

all surveying work needed to insure that the duct structure is constructed per the design.

- G. PERMITS - The Contractor is responsible for obtaining city permits (if allowed by local authorities), and all construction shall be in accordance with city specifications unless otherwise specified.
 - H. WORKING HOURS - Under normal working conditions, the placement of concrete shall be done between the hours of 8:00 AM - 4:30 PM on weekdays. TXU ELECTRIC DELIVERY inspector shall be notified a minimum of 2 hours prior to the delivery of concrete and shall be present during placement.
 - I. STREET CLEAN-UP - The Contractor shall be responsible for cleaning paved streets that have been soiled by their construction vehicles within 24 hours after notification, by the appropriate governing authority or Company Representative.
 - J. RAMPS - The Contractor may need to install ramps to protect street curbs from damage due to construction vehicle traffic.
 - K. TRAFFIC COORDINATION - Contractor shall have flag-men, road signs, etc. to coordinate traffic around the job site per city or state requirements.
 - L. SPOILS - All unused spoils shall be hauled off the job site by the Contractor.
 - M. AS-BUILTS - Contractor shall supply TXU ELECTRIC DELIVERY one set of as-built drawings upon completion of the job.
 - N. DESIGN CHANGES – Contractor shall submit a written request to the appropriate TXU ELECTRIC DELIVERY Authorized Personnel prior to any modification to the original design drawings that will change the number of bends or add 10 percent or more to the overall conduit length found on the original design plan. This written request must be provided prior to implementation of change.
- V. **COMPANY RESPONSIBILITY** - The following shall be performed by and be the responsibility of the Company:
- A. The Company inspector is to inspect all manhole installations prior to the placing of backfill and all conduit installations prior to the placement of concrete.

- B. The Company inspector is responsible for coordinating all field changes with Engineering.
- C. All testing of concrete and backfill, which are deemed necessary by the Company, shall be performed by a local testing laboratory at the Company's expense.

VI. CONTRACTOR'S RESPONSIBILITY - The following shall be performed by and be the responsibility of the Contractor:

- A. The contractor shall notify TXU ELECTRIC DELIVERY Inspector a minimum of 24 hours before scheduling the pouring of concrete.
- B. **CONCRETE ENCASED DUCT STRUCTURE INSTALLATION**
 - 1. All conduit shall be concrete encased with a minimum of 3" of concrete. The top conduits of any duct structure shall have a 3" or 6" minimum cover depending on location site. Refer to construction drawings for duct section. All concrete encasement shall have a pattern finish.
 - 2. Concrete: 5 sack Portland Type I cement, 3/4" maximum size aggregate, 3000 PSI @ 28 days. The slump of the concrete may be increased by the Contractor, with the approval by the Company inspector or approved TXU ELECTRIC DELIVERY representative, in order to facilitate a wetter mix to insure total encasement of the duct. However, the slump should not be increased to the point where the ultimate yield strength of the concrete is jeopardized.
 - 3. Placement: All concrete shall be installed by the use of a hopper, trimmie, chute, or pump truck unless otherwise specified by TXU ELECTRIC DELIVERY inspector. At no time shall concrete be placed with a front-end loader or any other similar type of machinery.
 - 4. The duct structure shall be held down with screw-jacks (or by equivalent means) at 20 ft. maximum intervals in order to prevent floating or racking of the duct during placement of the concrete.

5. Conduit, bends, elbows and coupling: PVC conduit shall be minimum 6" type DB, TC-6 DB-60/ASTM F-512, 90 degrees centigrade rated or greater unless otherwise specified. All PVC 6" bends and elbows shall have a 36" radius. See attached sketch for any deviation in conduit size.
6. Spacers: Carlon #288RLN (Base) and 289RLN (intermediate) or other TXU ELECTRIC DELIVERY approved spacers shall be spaced at 5' intervals (max). **Spacers will be required and tied together with non-metallic tie-wraps.** Spacers shall also be used to "hold-down" the top row of ducts.
7. When complete, each conduit installed will be checked by pulling both a mandrel and a swab through the entire length of conduit. A swab cannot detect a break with a concrete buildup.

C. MANHOLE INSTALLATION

1. Manhole: Precast type, unless otherwise noted, should be supplied by Brooks/Old Castle (or other approved supplier) and be octagonal shape, 3-sections 15,000 lbs./section unless otherwise specified. (See attachment)
2. Preparation: 6 inches minimum pea gravel of cushion shall be installed in the bottom of the excavated area prior to the manhole installation. Sand base may be used with Project Manager's approval.
3. Installation: A crane will be required to install all manholes, and it is the Contractor's responsibility to obtain the crane. Approved sealant is required on all interfaces (supplied with manholes).
4. Backfill: Select backfill should be installed around manholes and compacted to 95% minimum or flowable material shall be used as select backfill when requested.
5. Entrance grade: The Contractor shall install the frame/cover and neck. TXU ELECTRIC DELIVERY construction plans show the approximate entrance elevation, however it is the Contractor's responsibility to install the necessary amount of neck to bring the top of the cover 2" above finished grade (or flush with street grade when cover is in street). Saw cutting or grout-fill may be required to obtain the appropriate entrance elevation.

6. The Contractor shall supply one (1) 8' x 5/8" copper clad ground rod, weld type, in each manhole. Ground rod shall be vertically driven into undisturbed soil. If rock is encountered, grounding shall be as directed by TXU ELECTRIC DELIVERY inspector.

7. Concrete pad: The Contractor shall install a 5' x 5' x 6" concrete pad around all manhole entrances in all non-paved areas. See attached drawing for reinforced steel requirements.

D. BACKFILL AND COMPACTION

1. Top Soil: Existing top soil shall be replaced. Top soil shall be free of all rock and clay.

2. Backfill: The backfill operation shall begin after the concrete has had time to cure. The curing time is at the discretion of TXU ELECTRIC DELIVERY inspector. The backfill shall have no rocks larger than 6".

3. Compaction: 95% minimum requirement

4. Lifts: 1 foot lifts (maximum)

5. Compaction Test: TXU ELECTRIC DELIVERY responsibility

6. Final Grade Elevation: The Contractor shall return the excavated area back to the developer's original grade elevation.

E. SUBSTATION FEEDER EXIT INSTALLATION - This covers the procedures and materials to be used during site work at TXU ELECTRIC DELIVERY substations or switching stations.

1. Company privileges - The Company's Authorized Representative shall have the right to test, at Company expense, all materials secured and work performed.

2. Substation Ground Repair - Substations generally have grounding systems consisting of copper wires buried 1-3 feet beneath the surface which attach to substation structures and perimeter fences. These ground grid wires may exist at any location inside the substation to a few feet outside the substation fence. If this ground grid wire is damaged, the CONTRACTOR shall notify TXU ELECTRIC DELIVERY and repair the damage. Repair to damaged ground grid wire shall be made to TXU ELECTRIC DELIVERY standards. Most repairs to the ground grid wire may be made as shown on TXU ELECTRIC DELIVERY drawing GNDREPAIR (See attachment p.22). If the scope of the repair required to the substation grounding system is greater than that shown on GNDREPAIR, contact TXU ELECTRIC DELIVERY.
3. The Contractor shall maintain access to the work site at all times.
4. Backfill - The Contractor shall backfill all excavations made during the clearing and grubbing operations with compacted fill material. Fill material, placement, and finishing shall comply with the provisions of Section E-6 thru E-8 and as found on attachment (page 12) .
5. Excavating
 - a. The Contractor shall excavate to the contours, grades, and elevations indicated on the grading plan.
 - b. Excavated materials, suitable for use as fill as determined by the Company's Authorized Representative, shall be placed in compliance with the provisions of Section E-7 in fill or embankment areas indicated on the grading plan.
 - c. The Contractor shall haul and dispose of all surplus excavated materials. Disposal shall be away from the site, unless otherwise noted. The Contractor shall meet the requirements of regulatory authorities regarding proper disposal.
6. Fill Material
 - a. Excavated material, with prior approval by the Company's Authorized Representative, may be used as fill material.

- b. Prior to hauling in fill material, the Contractor shall inform the Company's Authorized Representative of the location of the proposed fill material so that samples may be obtained for required tests.
- c. Soil suitable (per 6.b.) for use as fill material shall be free from organic matter and deleterious substances and shall contain no rocks or stones larger than one inch in diameter.
- d. The soil shall be classified as sandy clays or clayey sands having a Plasticity Index (PI) greater than 4 and less than 12 and a Liquid Limit (LL) less than 30. The Company shall pay for a maximum of two series of the above tests. Any additional tests required by failure of the material to meet the requirements shall be performed at the expense of the Contractor.
- e. If the tests performed on the proposed fill material yield satisfactory results, the fill material shall then be tested in accordance with "Maximum Density-Optimum Moisture Test" ASTM-D698 (Standard Proctor Test), and the results used in compaction.

7. Filling

- a. The Contractor shall fill to the contours, grades, and elevations indicated on the grading plan.
- b. Fill material shall be placed in lifts not exceeding 12 inches in uncompacted thickness, sprinkled, rolled, and compacted to a minimum of 90% of maximum dry density as determined by ASTM D-698.
- c. Water necessary to obtain proper moisture content for compaction shall be furnished by the Contractor.

8. Finish Grading

- a. The Contractor shall fill to the contours, grades, and elevations indicated on the grading plan.
- b. The Contractor shall correct all imperfections, discovered during finish grading, by scarifying the area affected, adding or removing material as required, reshaping, and recompacting.
- c. The Contractor shall not apply yard covering until the subgrade has been approved by the Company's Authorized Representative.

9. Yard Covering (crushed limestone) - The crushed limestone shall conform to Texas State Department of Highways and Public Transportation's 1982 Standard Specifications for Construction of Highways, Streets and Bridges, Item 248.

10. Application of Yard Covering

- a. The Contractor shall apply, to all areas indicated on the grading plan, sufficient yard covering to obtain a minimum of four inches after compaction.
- b. Yard covering shall be compacted to a minimum of 90% of maximum dry density as determined by ASTM D-698.
- c. Under no circumstances shall the Contractor add thin layers of fine materials to yard covering in order to meet the final grade.

11. Application of Base Material (Roads and Parking Areas)

- a. The Contractor shall, unless otherwise noted, supply base material which complies with the provisions of Section E-9.

- b. The Contractor shall apply, on all limestone roads and parking areas, sufficient base material to obtain a minimum of six inches after compaction.
- c. Base material shall be compacted to a minimum of 95% of maximum dry density as determined by ASTM D-698.
- b. Under no circumstances shall the Contractor add thin layers of fine materials to base material in order to meet final grade.

12. Final Grading (Roads and Parking Areas)

- a. The final grading shall provide smooth and uniform surfacing and shall be approved by the Company's Authorized Representative.
- b. The Contractor shall correct all imperfections discovered during final grading by scarifying the area affected, adding or removing material as required, reshaping, and recompacting.

VII. VARIANCES

- A. Variances to these specifications shall be submitted in writing to and approved by the Company prior to construction.
- B. Any approved variance shall apply only to the particular project for which it was submitted.

VIII. ATTACHMENTS

TYPICAL DUCT SECTION

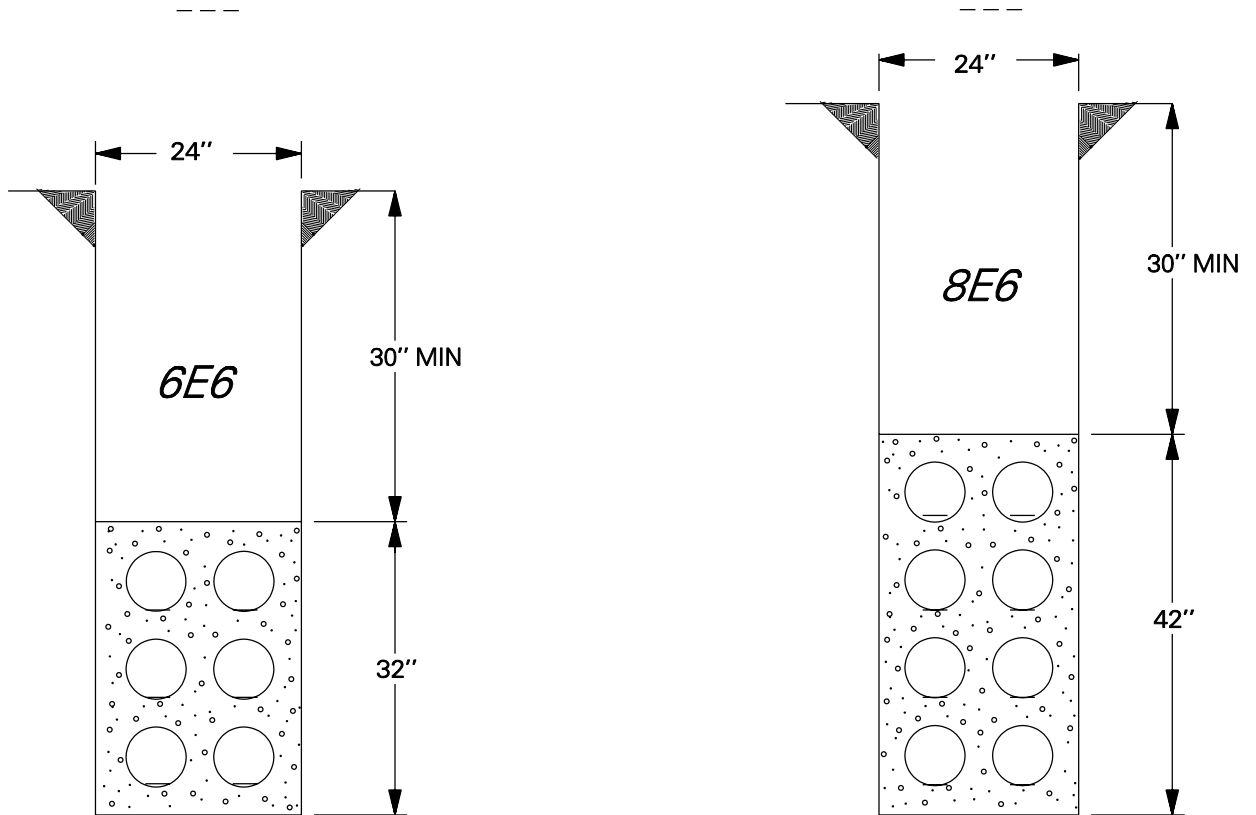
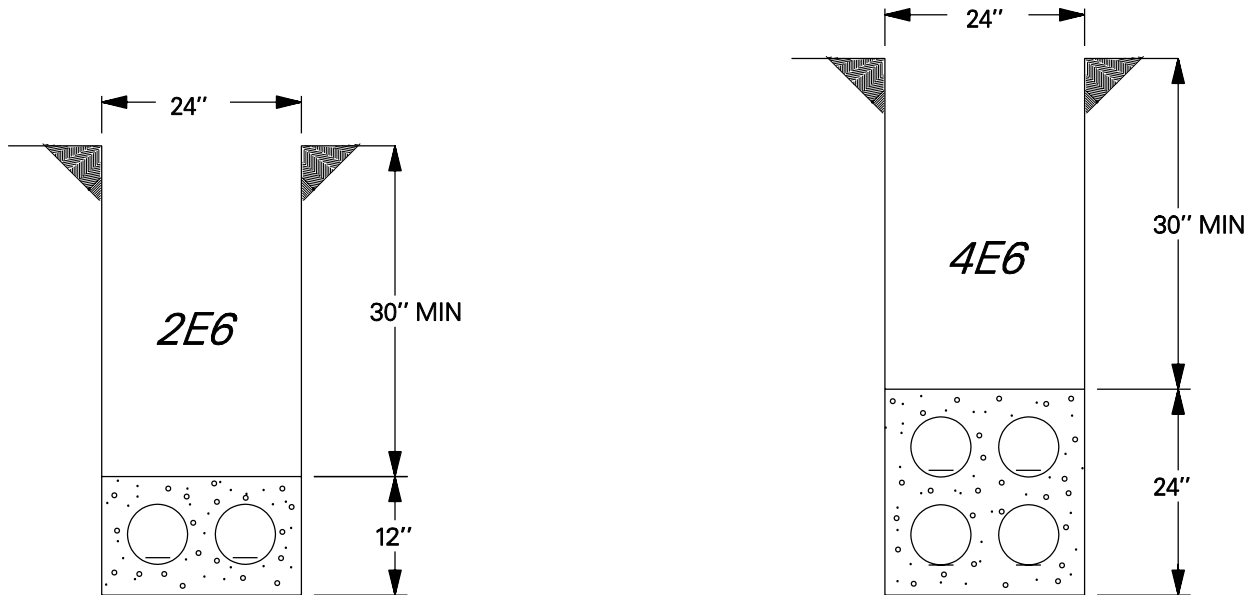

APPROVED BY TXUElectric Delivery12

4 WAY MANHOLE

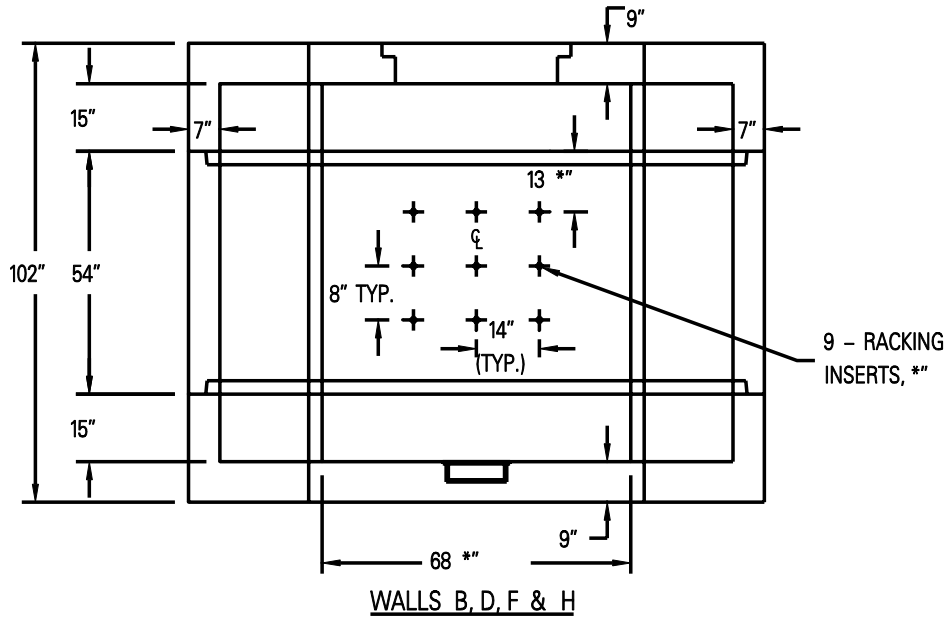
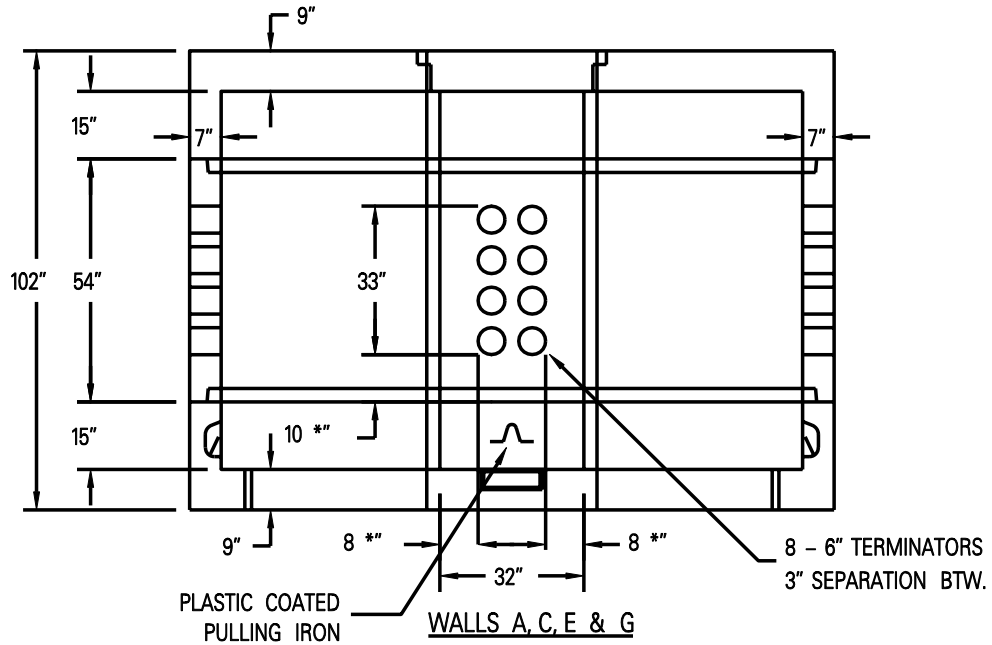

APPROVED BY TXUElectric Delivery14

3 WAY MANHOLE

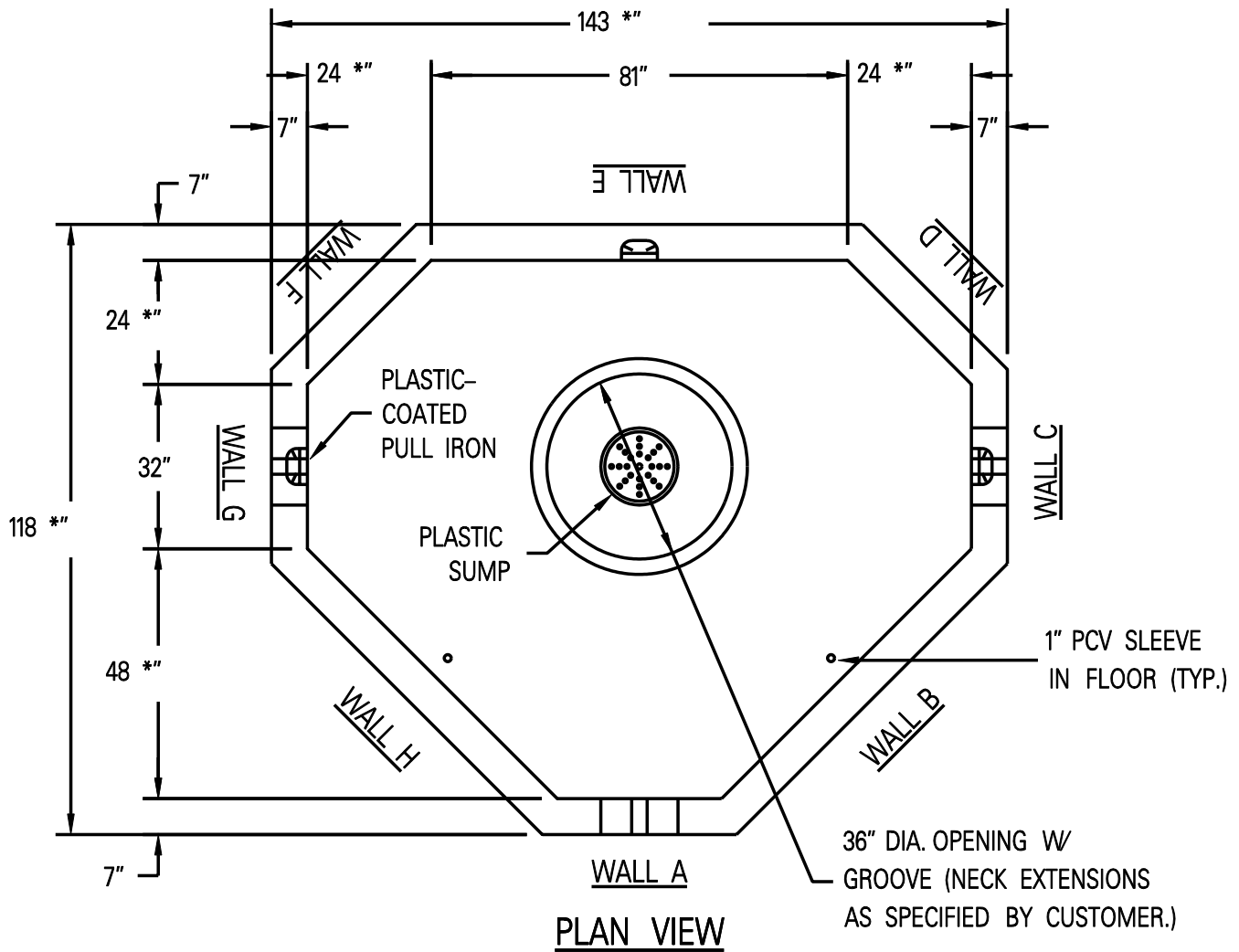

APPROVED BY TXUElectric Delivery15

3 WAY MANHOLE

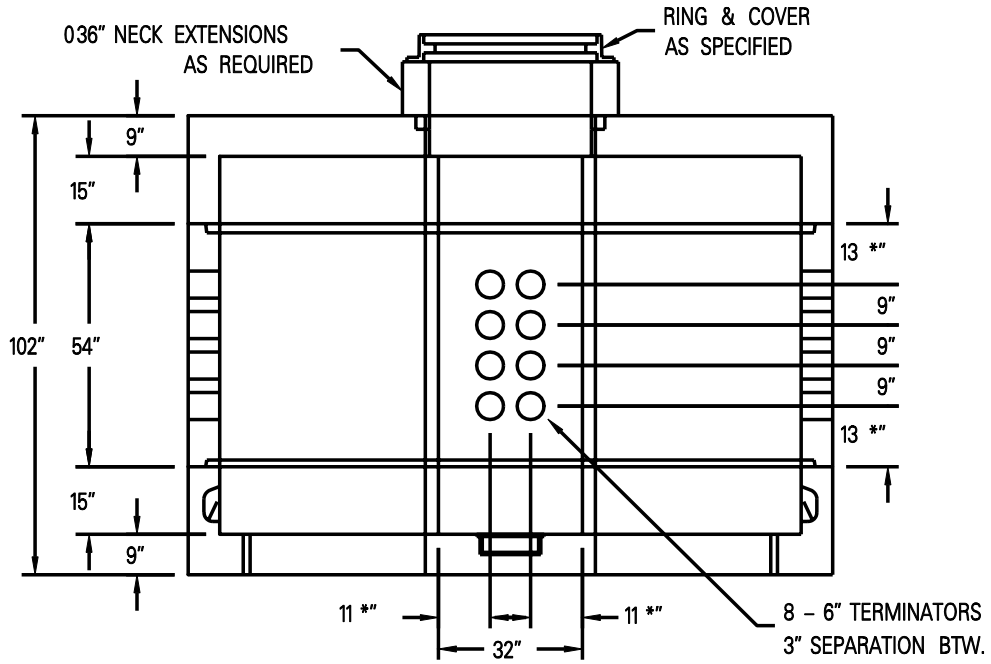

WALL A

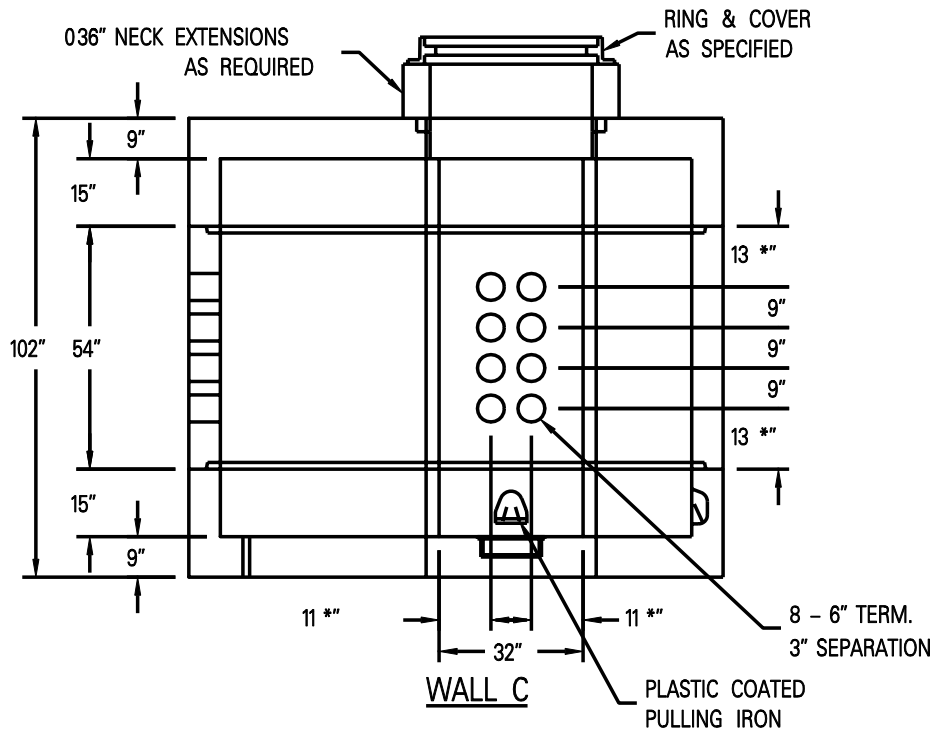

WALL C

APPROVED BY TXUElectric Delivery16

2 WAY MANHOLE

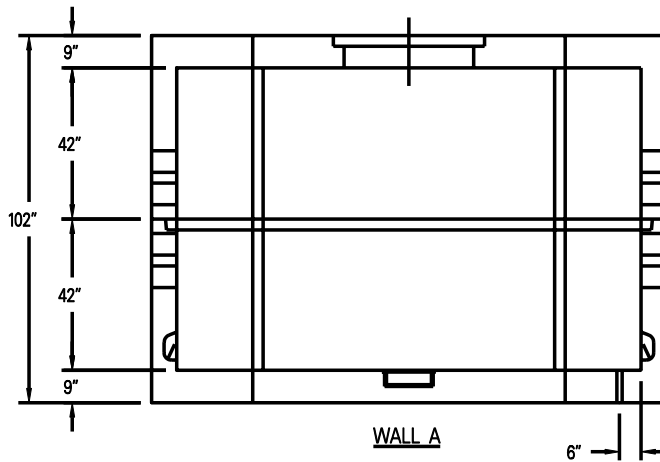
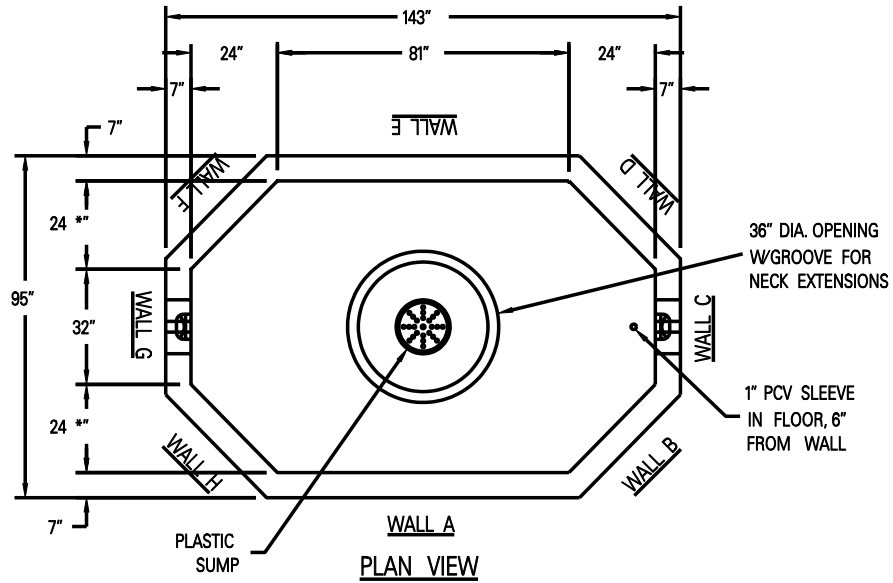

APPROVED BY TXUElectric Delivery17

MANHOLE NECK

TOP VIEW

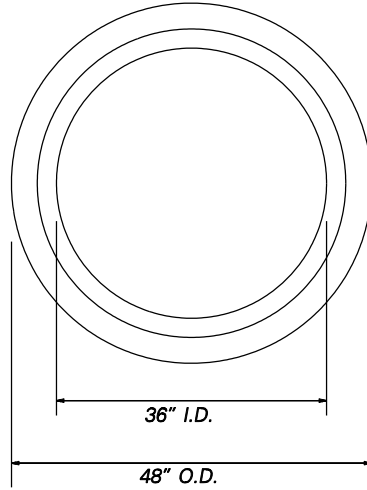

SIDE VIEW

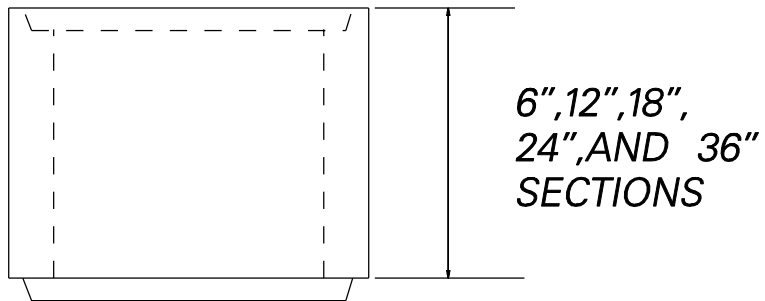

APPROVED BY TXUElectric Delivery18

CONCRETE SLAB
FOR MANHOLE CASTING

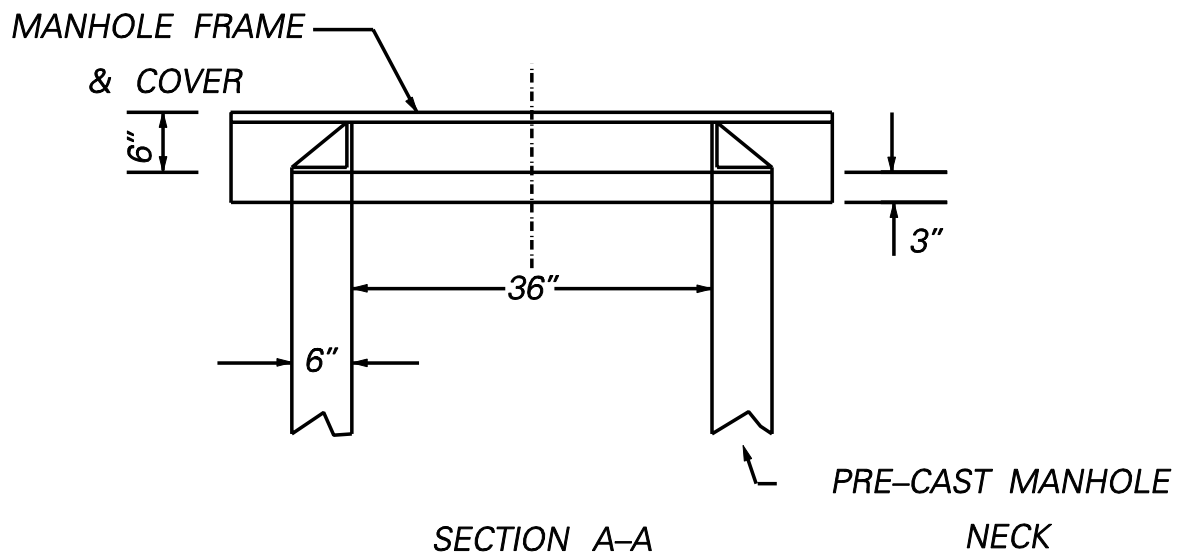
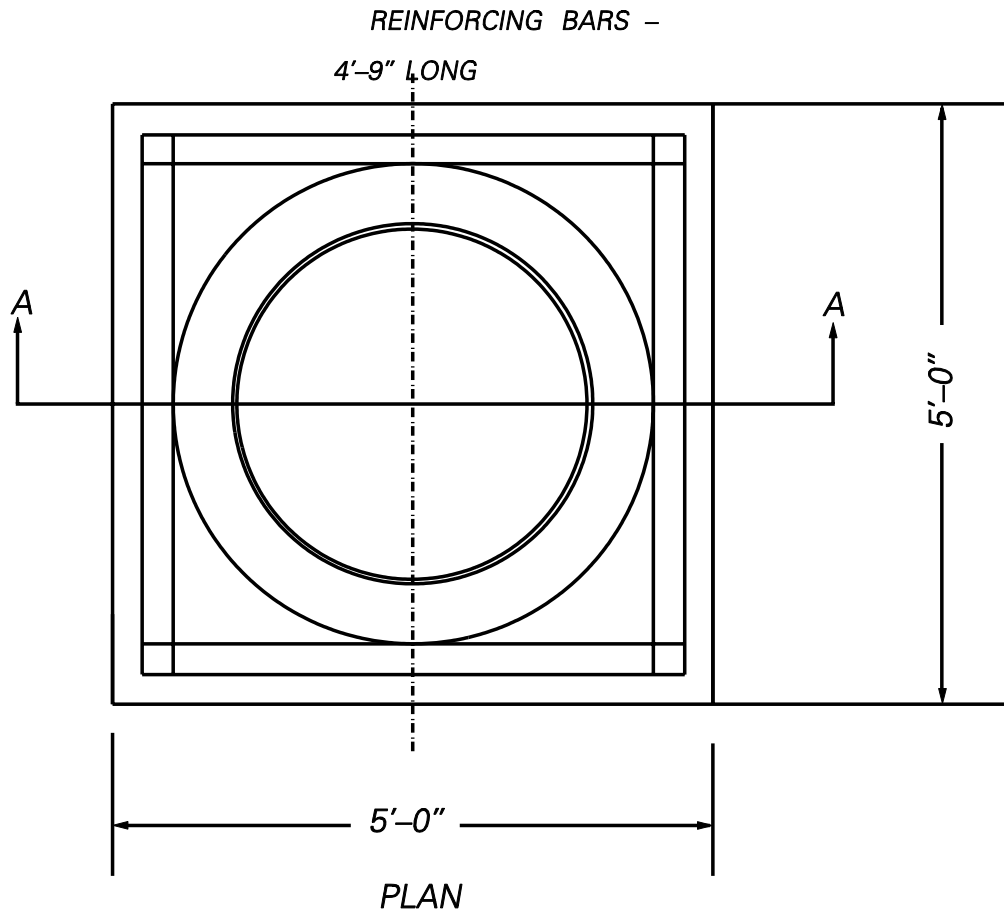

APPROVED BY TXUElectric Delivery19

TERMINATION OF CONDUIT LINE FOR FUTURE USE

STAIR STEPPED COLD JOINT WITH ELECTRONIC CONDUIT MARKER

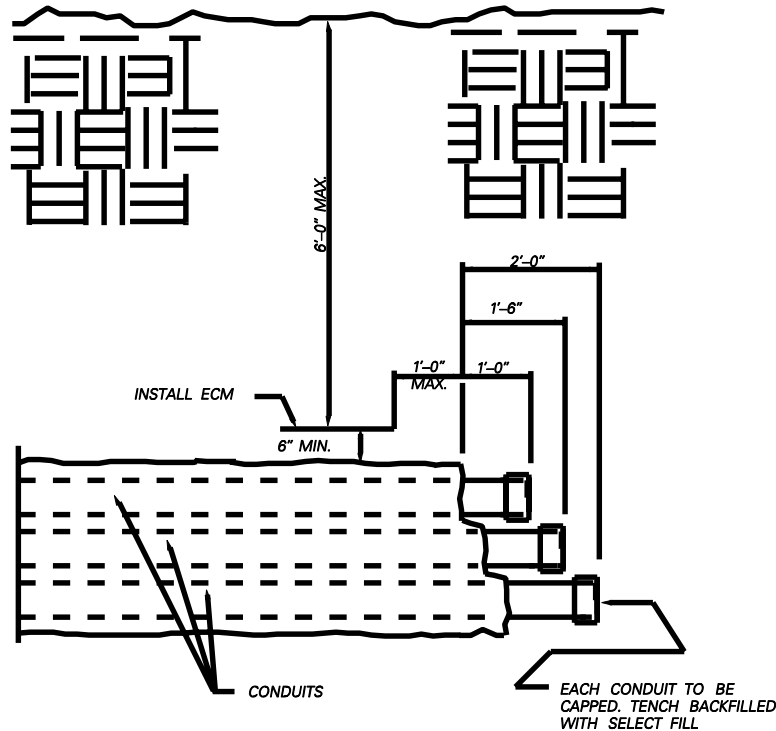

ELECTRONIC CONDUIT MARKER (ECM)

1. CONTRACTOR, UNLESS OTHERWISE NOTED IS RESPONSIBLE FOR OBTAINING AND INSTALLING THE ECM.
2. CONSULT TXU ELECTRIC REPRESENTATIVE FOR APPROVED ECM.
3. ECM SHALL BE BURIED DIRECTLY OVER AND A MIN. OF 6" ABOVE DUCT INSTALLATION AND NO MORE THAN 6' BELOW FINAL GRADE.
4. ECM SHALL BE INSTALLED FLAT AND LEVEL. SEE PLAN SHEETS FOR LOCATION.
5. ECM SHALL BE COVERED WITH 4" OF FIRM SOIL TO PREVENT MOVEMENT OR DAMAGE DURING BACKFILL.

INCOMPLETE DUCT LINE

1. ON ALL INCOMPLETE DUCT LINES (DUCTS THAT ARE TO BE EXTENDED AT A FUTURE TIME). THE CONDUITS ARE TO BE WATERTIGHT WITH A CONDUIT CAP SOLVENT CEMENTED INTO PALCE.
2. DOWELLING IS THE METHOD TO BE USED IN ORDER TO JOIN NEW DUCT TO EXISTING UNFINISHED DUCT. INSTALL #5 DOWELL WITH 8 INCHES MINIMUM EMBEDMENT.

APPROVED BY TXUElectric Delivery20

TERMINATION OF CONDUIT AT RISER POLE

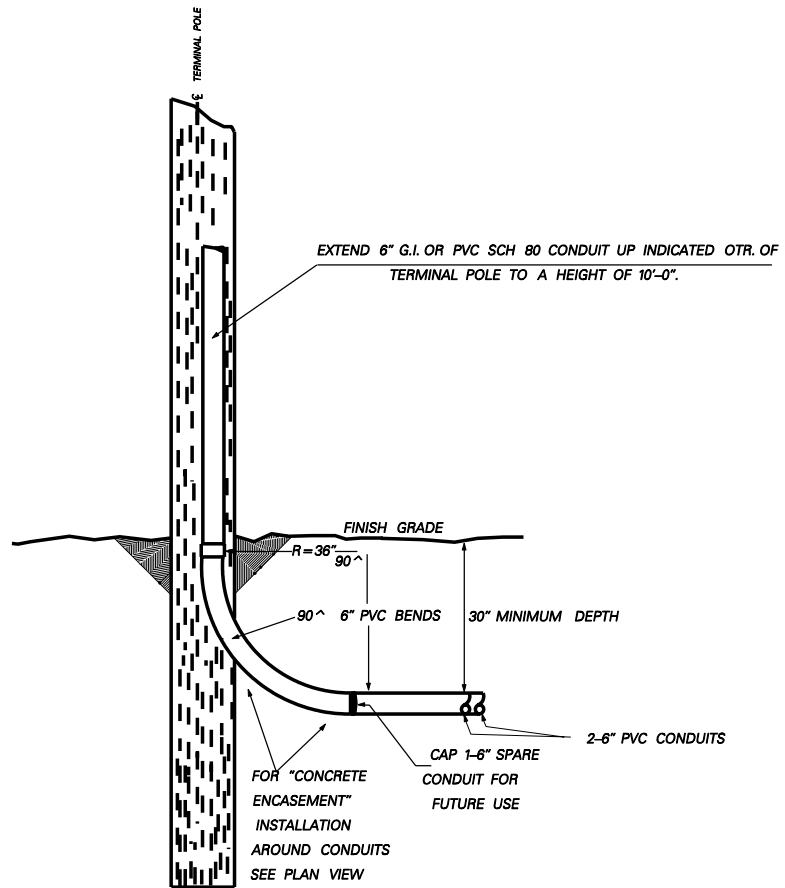

DO NOT BEND CONCRETE TO POLE

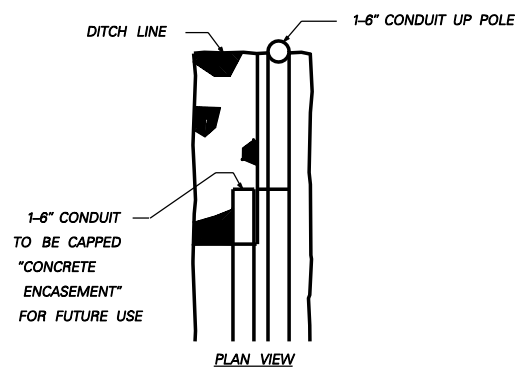

APPROVED BY TXUElectric Delivery21

SUBSTATION GROUND WIRE REPAIR DETAIL

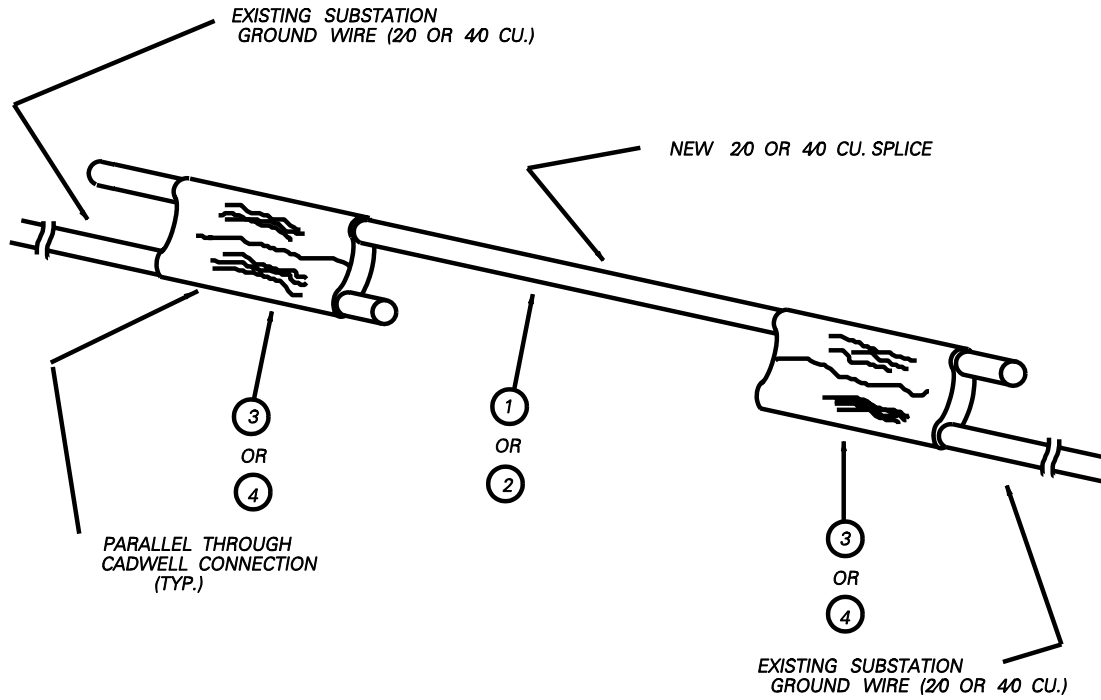

ITEM	DESCRIPTION	TSN	CADWELD PART NUMBERED
1	WIRE 20 CU.	303252	NA
2	WIRE 40 CU.	303253	NA
3	MOLD PARALLEL THROUGH FOR 20 CU. WIRE	322111	PTC-2628
4	MOLD PARALLEL THROUGH FOR 40 CU. WIRE	322112	PTC-2020
5	WELD METAL 115 (FOR ITEM 3)	308031	115
6	WELD METAL 200 (FOR ITEM 3)	308032	200
7	HANDLE (FITS ITEM 3 AND 4)	287995	L-160
8	MOLD CLEANER	322132	B-136-3
9	FLINT IGNITOR GUN	386189	T-320

APPROVED BY TXUElectric Delivery22

SWITCHGEAR PAD DETAIL

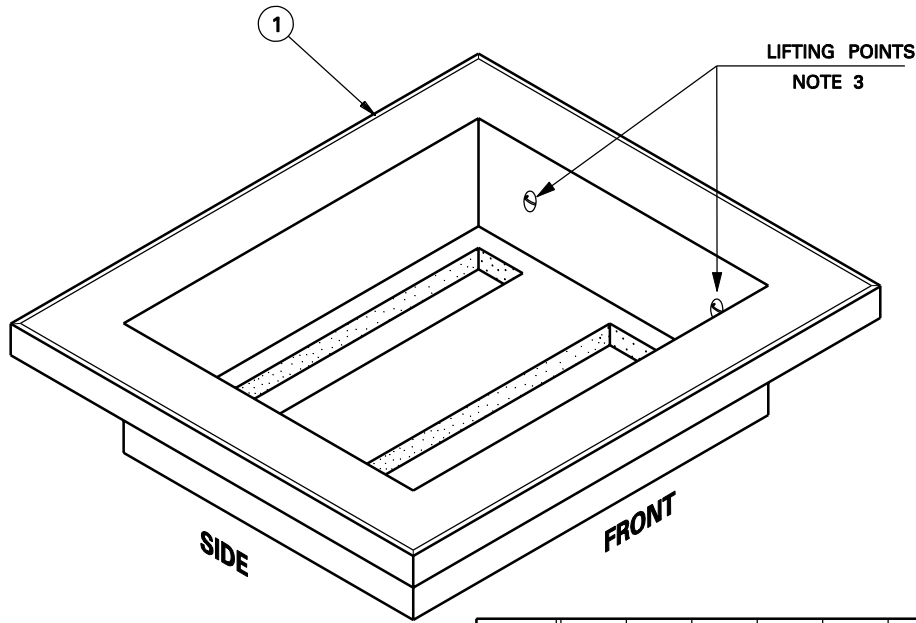

INCHES	A	B	C	D	E	E2	F	G	G2	W	X
25KV	100	76	62	86	40	18	48	44	16	68	14
15KV	84	60	50	74	30	15	36	38	11	52	14

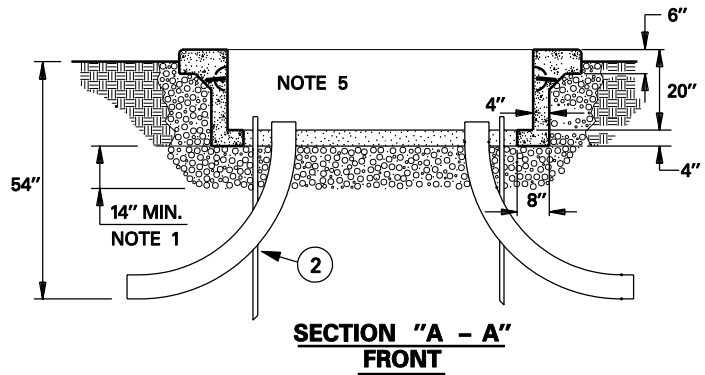
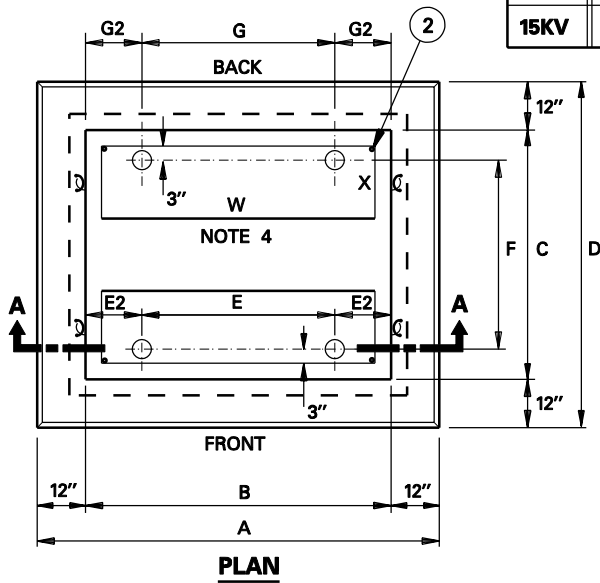

NOTES:

1. INSTALL 14" MINIMUM SMALL TO MEDIUM GRAVEL BASE. INCLUDE MINIMUM 12" GRAVEL FILL AROUND SIDES.
2. FOR CLEARANCES ON ALL SIDES OF THE SWITCHGEAR SEE REFERENCE DRAWING 202-100.
3. EACH PAD WILL INCLUDE FOUR - LIFTING POINTS RATED AT 2000 LBS EACH.
4. WHEN INSTALLING SPARE CONDUIT, CENTER DIMENSION LINES BETWEEN CONDUITS.
5. CONDUIT NOT TO EXTEND MORE THAN 3" ABOVE BOTTOM OF DEEPWELL.

APPROVED BY TXUElectric Delivery23

MANHOLE FRAME & COVER

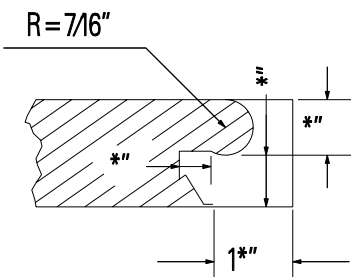
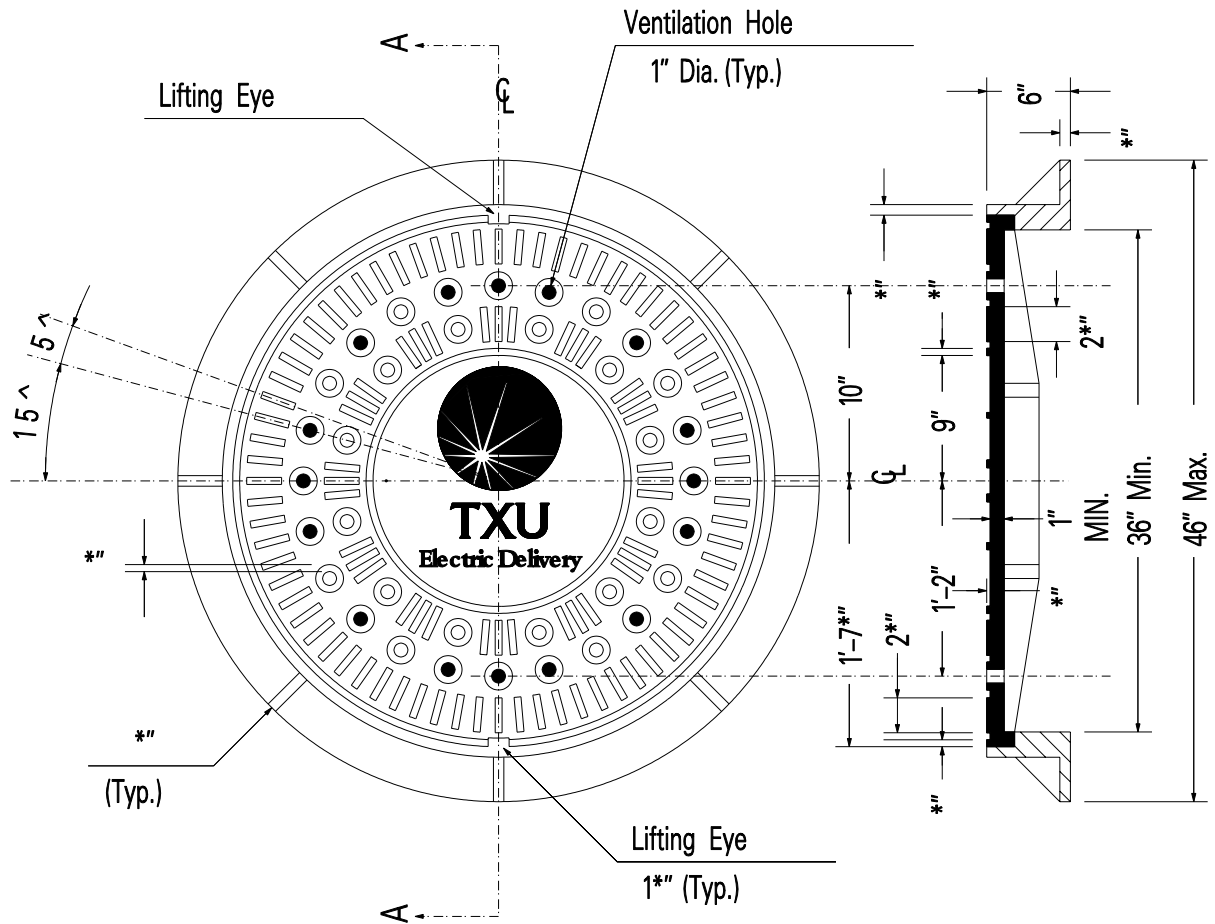

Lifting Eye Detail

GENERAL NOTES

Bearing surface between cover and frame shall be machined.

Cover and frame shall be constructed to H-20 traffic loading.

Cover and frame shall be constructed of gray cast iron.

Manhole cover and frame shall not exceed 700 lbs.

APPROVED BY TXU Electric Delivery 24